

# POWER *FLOW*

## UNVENTED HOT WATER SYSTEM ANNUAL SERVICE REQUIRED

### INSTRUCTIONS

#### *PLEASE LEAVE WITH HOUSEHOLDER*

**IMPORTANT** - Failure to install and maintain this system in accordance with these instructions will invalidate the manufacturer's warranty. Extended warranty card to be completed and returned.



# McDonald Water Storage

QUEENSWAY INDUSTRIAL ESTATE,  
GLENROTHES FIFE KY7 5QF  
Tel : 01592 611123 Fax : 01592 611166  
Email : [sales@mcdonaldwaterstorage.com](mailto:sales@mcdonaldwaterstorage.com)  
Internet : [www.mcdonaldwaterstorage.com](http://www.mcdonaldwaterstorage.com)

**FOR SPARES CALL 01592 611123**

**WRAS**  
APPROVED  
PRODUCT

# IMPORTANT

Installation should only be carried out by a 'competent operative' i.e. the installer must have attended a recognised course in Unvented Hot Water Systems or received appropriate training in their apprenticeship. All registered operatives should carry an Identification Card issued by their certificate provider – for example BPEC or SNIPEF. Installation should be carried out in accordance with current local Building Regulations and water Byelaws.

The **POWERFLOW** unit should be handled with care in order to avoid damage to valves. It should be stored upright in a dry place.

Full weights are available on page 7 of this booklet. The installation area should be able to cope with this weight, incoming pipes and discharge pipe. Position the unit to suit the installation.

Generally connections are to the front to enable ease of access. Alternatively if a sketch is provided refer to that. Ensure suitable space is left for access for repair and/or replacement of valves etc.

In areas with hard water we would recommend restricting the temperature and performing de-scaling procedures as required.

**All the following instructions must be carried out: -**

1. Installers should ensure incoming mains pressure is less than 12Bar and that local authority approval for installation of Unvented Systems is granted. Ensure adequate flow-rate is available.
2. Excessive use of flux can damage the unit and especially the valves and expansion vessel. Avoid over-use and

ensure the system is fully flushed of any debris or flux before connection.

3. Incoming mains to arrive in a minimum of 22mm copper pipe. Fit to the Pressure Reducing Valve A (See Page 4) set at 2.1 Bar. Contract Models 1.5 Bar and 3 Bar Models – 3 Bar. This includes a serviceable Strainer. We would strongly recommend this valve is fitted where the mains enters the property, but it can go wherever is most suitable for the installation, between the mains stopcock and the cylinder.

**We recommend fitting a Tee between the Pressure Reducing Valve (A) and the Check Valve (A2) to provide a BALANCED COLD OUTLET for all cold taps**, preventing cross-flow and also giving potable water throughout the house. **Outdoor taps for hoses should be taken before the Pressure Reducing Valve.**

4. The Check Valve (A2) is supplied loose, to be fitted between the Pressure Reducing Valve and before the Expansion Vessel on the Cold Feed. Any balanced cold draw off should be fitted between the Pressure Reducing Valve (A) and the Check Valve (A2).
5. The Temperature & Pressure Relief Valve (D) set at 90°C and 4.5 Bar (3 Bar models set at 7 Bar), and the Expansion Relief Valve (B) set at 3.5 Bar (Contract Model 3 Bar and 3Bar Models 5 Bar), should be fitted and connected to the Tundish (E). NB - the relief valves are only to be used for relief discharge purposes.

No valves should be fitted between the relief valves and the cylinder.

6. The Tundish (E), which shows visible discharge from the Relief Valves, is to be in a prominent, visible and safe position away from any electrical devices (likewise with the drain connection) and within 500mm of the Temperature & Pressure Relief Valve (D). Pipework from the Tundish (E) must initially be vertical for a minimum of 300mm where possible and then have a continuous fall in excess of 1 in 200. Pipework away from the Tundish (E) should be in a minimum of 22mm, of material suitable for temperatures of 95°C and have a resistance to flow of water not greater than that of a straight pipe of 9 metres (each bend or elbow is equal to 0.8 metre of resistance). See BBA Information. Sheet No 33:1989 for further details - available from the manufacturer. Also note page 9 of these instructions.
7. The Expansion Vessel (F) should be set the same as the Pressure Reducing Valve (A) - 2.1Bar (Contract Models 1.5Bar and 3Bar Models 3Bar). The Expansion Vessel should be fitted to the wall and connected to the Tee (F1), between the Check Valve (A2) and Cold Feed, (hard piped or fitted with the braided flexi-hose). (On previous units the check valve was factory fitted to the Cold Feed). No isolating valve is allowed between the Vessel and the Cold Feed. The Vessel must also be fitted within 2m of the cylinder.
8. Connect the 3kW 11" 240V Immersion Heater/s BSEN 60335/2/73 (with manual re-set cut out at 80°C) to the power supply and earth them in accordance with the current IEE wiring regulations. The fuse rating should be 13 Amps. **Do not at any time fit Immersion Heaters without a thermal cut-out.**
9. On Indirect Units where a Coil is fitted to the cylinder, when supplied, the Two Port Motorised Zone Valve and Dual Thermostat Controller (J) must be fitted in accordance with the instruction details supplied with them for the appropriate installation. See back page for Solar & Heatpump coils  
**N.B. Indirects, are suitable for oil, gas and electric fired boilers on a pumped, gravity or sealed system. (We would however recommend 28mm Coil connections with a 28mm Zone Valve on gravity systems). Maximum working pressure of the coil is 3.5 Bar.** All electrical wiring to thermostats, zone valve and immersion heaters must be earthed and to current IEE Wiring Regulations. The fuse should generally be 3 Amps but refer to appliance instructions to confirm this.
10. The Secondary Return (L) if supplied, should be plugged if not required. If the Secondary System pipe-work is greater than 15% of the unit capacity, a larger Expansion Vessel may need to be fitted - contact McDonald Water Storage.
11. Immersion Heaters (H) and the Dual Thermostat Controller (J) supplied with the Indirect units should be set to no greater than 60°C and the internal High Limit Thermostats are factory set no higher than 85°C. **Always check this before switching on power.** (Immersion Heaters - 1 = 10°C, 2 = 25°C, 3 = 40°C, 4 = 55°C, 5 = 70°C). Please see the checklist on page 4 to ensure all controls are present and correct.

# ONCE ALL THE PRECEDING INSTRUCTIONS HAVE BEEN FOLLOWED, COMMISSION THE SYSTEM.

## IMPORTANT

### COMMISSIONING - These instructions must be followed.

After following the instructions on pages 1 & 2 proceed as follows: -

1. Close the *Drain* (I) at base of cylinder.
2. Open a Hot Tap.
3. Fully open the Cold Mains Stopcock and fill Cylinder until water appears at the Hot Tap.
4. Close the Hot Tap and attend each hot water outlet in turn and ensure water flow is obtained at each.

IT IS THE RESPONSIBILITY OF THE INSTALLATION ENGINEER TO CHECK AND ENSURE THAT ALL VALVES, FITTINGS AND IMMERSION/S ARE PROPERLY SEALED AND WATERTIGHT.

5. Check the control thermostats on the *Immersion Heater/s* (H) and the *Dual Thermostat* (J) are set no higher than 60°C and that the High Limit Thermostats are set to no higher than 85°C.

6. Ensure there is no discharge from the Relief Valves (B and D).
7. Switch on water heating system and check operation of the system.

IT IS EXTREMELY IMPORTANT TO FOLLOW ALL THE INSTRUCTIONS PREVIOUSLY MENTIONED, AS FAILURE TO DO SO COULD BE DANGEROUS OR LEAD TO THE SYSTEM WORKING INEFFICIENTLY.

## SPARES CODES

Below is a list of the codes for the **POWERFLOW** spares, available on the website:

- WUVPR** – Pressure Reducing Valve 2.1 B
- WUVPR3** – Pressure Reducing Valve 3.0 B
- WUVPRC** – Pressure Reducing Valve 1.5 B
- WUVC** – 22mm Check Valve
- WU12EV** – 12L Expansion Vessel  
(Other sizes available: 8, 18, 24, 33)
- WUVER** – 15mm Exp. Relief Valve 3.5 B
- WUVTP** – 15mm P & T Relief Valve 4.5 B
- WUEIH** – 3kW Immersion Heater
- WUTUND** – 15 x 22mm Tundish
- WUEDAC** – Dual Thermostat
- WUEMZV22** – 22mm Motorised Zone Valve

Other sizes and pressures available on our website:

[www.mcdonaldwaterstorage.com](http://www.mcdonaldwaterstorage.com)

## Schematic Layout of Valves

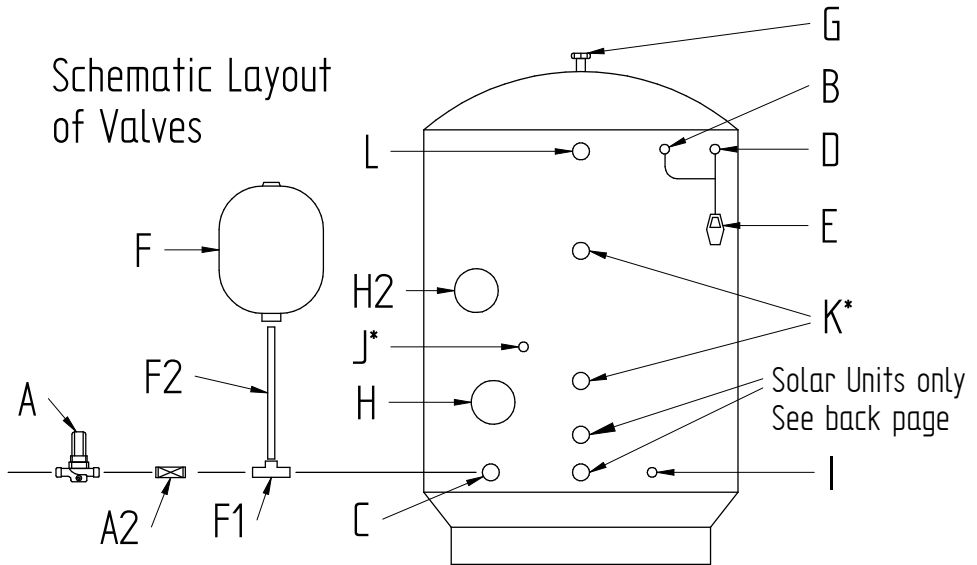

## CHECKLIST

**A - Pressure Reducing Valve with Strainer.**

**A2 - Check Valve.**

**B - Expansion Relief Valve.**

**C - Cold Feed.**

**D - Pressure & Temperature Relief Valve.**

**E - Tundish.**

**F - Expansion Vessel.**

**F1 - Tee Compression for Expansion Vessel.**

**F2 - 1m Braided Flexi-Hose (or hardpiped)**

**G - Hot Water Draw Off.**

**H - Immersion Heater 80°C cut-out.**

**H2 - Optional Second Immersion on Indirects. Standard on 150 Directs upwards.**

**I - Drain connection.**

**J\* - Dual Thermostat Controller.\***

**K\* - 22mm Connections to Primary Coil. The Zone Valve should be fitted and also a High Limit Stat fitted to the Boiler.**

*For Solar and Heat pump coils see back page.*

**L - 22mm Secondary Return. Plug if not required (only on 180 litre units upwards as standard – or on request).**

**\*Indirects only**

## **ANNUAL MAINTENANCE**

**POWERFLOW** should be serviced at least once a year by a competent operative.

**IMPORTANT** - failure to maintain this system in accordance with these instructions will invalidate the manufacturer's warranty. A maintenance record should be kept on the **ANNUAL SERVICE RECORD** card provided on page 10, we would recommend a service programme is arranged on installation.

**Failure to maintain this record will invalidate the manufacturer's warranty. Contact your installer to arrange the appropriate service program.**

## **ANNUAL SERVICE CHECKS**

**Expansion Relief Valve (B)** - manually open the twist cap and check that the water is discharged and runs clearly through the Tundish (E) and out at the final discharge point. Ensure that the valve re-seats/re-seals itself.

**Pressure & Temperature Relief Valve (D)** - repeat the above procedure. Ensure that the valve re-seats/re-seals itself.

**Strainer (A)** - turn off mains at stopcock. There will be a small amount of residual water in the pipework, remove the cartridge from Pressure Reducing Valve (A), clean Strainer and replace.

**Expansion Vessel (F)** - Check Pressure via the valve under the black cap on top of the vessel, while a hot tap is running. Ensure pressure is as per section 7 on page 2. Vessel can be re-charged if required as per "Recharging Expansion Vessel" on page 6 opposite.

## **PROBLEM SOLVING**

**DISCHARGE FROM EITHER OF THE RELIEF VALVES INDICATES A MALFUNCTION IN THE SYSTEM AND MUST BE INVESTIGATED IMMEDIATELY.**

## **OVERHEATED HOT WATER DISCHARGE**

In the unlikely event of overheated (90°C) water being discharged, the heat source i.e. the immersion heaters or the central heating boiler should be switched off immediately and a competent operative called out. Ensure that the discharge of hot water or steam at the *Tundish* (E) or final discharge point causes no danger and is not likely to injure anyone.

**DO NOT SHUT OFF THE COLD WATER SUPPLY TO THE UNIT!!**

**DO NOT RE-USE UNTIL CHECKED AND REPAIRED!!**

**ENSURE COMPONENTS ARE ISOLATED FROM ELECTRICITY BEFORE INVESTIGATION!!**

Once cold water has entered the unit and displaced the over heated water thus cooling it, check the thermostat and energy cut out in the a) Immersion Heater,

b) Thermostat, c) Boiler. Identify the faulty component and replace with the correct component as supplied by the manufacturer and ensure that it works before re-commissioning the system.

**DO NOT FOR ANY REASON BY-PASS AN ENERGY CUT-OUT.**

**Problem Solving continued on page 6...**

## **WATER DISCHARGE**

If water is occasionally being discharged as the water is heated, this would be likely to indicate that the Expansion Vessel (F) needs recharged. In the event of it occurring, switch off all power supplies to the cylinder, re-charge the vessel as below.

If water is continually being discharged, firstly check with a gauge that the pressure allowed through the *Pressure Reducing Valve (A)* does not exceed the setting as per section 7 page 2. If it does exceed, remove the filter and thoroughly clean. If this does not solve the problem, a replacement should be ordered from McDonald Water Storage. Next, check the charge in the expansion vessel and recharge as below. If the pressure is okay, check which valve is discharging and replace with a replacement supplied by McDonald Water Storage.

## **RECHARGING EXPANSION VESSEL**

To recharge the expansion vessel, close the mains stopcock and open a hot tap. Connect a pump with gauge to the air inlet on top of the vessel and charge to the same as the *Pressure Reducing Valve* - Page 2 Section 7

(14.7 P.S.I. x every 1bar)

Pressure	
1.5bar	22 P.S.I.
2.1bar	32 P.S.I.
3bar	44 P.S.I.

## **HOW TO DRAIN SYSTEM**

Switch off water at mains and open a hot tap. If not pre-piped, connect the *Drain (I)* to a hose and open, the cylinder will now start draining through the hose.

To re-fill follow the commissioning instructions on Page 3.

N.B. To flush out the system, drain the unit as above, fill and repeat.

## **IF PROBLEMS CONTINUE**

If after recharging the expansion vessel the cylinder is still discharging, it may be cross-flow - ensure appropriate check valves are fitted. The *Pressure Reducing Valve (A)*, one of the *Relief Valves (B or D)*, (as previously mentioned) or the *Expansion Vessel (F)* has failed. The component should only be replaced by a replacement part supplied by McDonald Water Storage. Contact McDonald Water Storage for further information.

## **IMMERSION HEATER FAILURE**

If the Immersion Heater (H or H2) is not heating the water it has either failed (In which case a replacement Immersion Heater as supplied by McDonald Water Storage should be fitted) or the electrical cut-out has operated due to the control thermostat being set too high or being faulty. (1 = 10°C, 2 = 25°C, 3 = 40°C, 4 = 55°C, 5 = 70°C).

On Indirect units it may be a faulty stat in the boiler is allowing the water to overheat and operating the Immersion cut-out.

(CHECK THE IMMERSION HEATER IS ISOLATED FROM THE MAINS)

Once these have been checked and/or replaced, the Immersion Heater can be re-set by taking off the cap and depressing the button in the Immersion Heater on the High Limit Stat

**Should any fault or problem arise not covered in this leaflet, please contact the manufacturer.**

## TECHNICAL DATA

Weights	Direct		Indirect	
	Empty	(kgs) Full	Empty	(kgs) Full
75 Litre <b>POWERflow</b>	24	99	26	101
120 Litre <b>POWERflow</b>	33	153	37	157
150 Litre <b>POWERflow</b>	39	189	44	194
180 Litre <b>POWERflow</b>	49	229	55	235
210 Litre <b>POWERflow</b>	55	265	61	271
300 Litre <b>POWERflow</b>	80	380	86	386

Heat Up Times 10-60°C	Direct	Indirect
75 Litre <b>POWERflow</b>	89 mins	21 mins
120 Litre <b>POWERflow</b>	129 mins	24 mins
150 Litre <b>POWERflow</b>	115 mins*	25 mins
180 Litre <b>POWERflow</b>	145 mins*	25 mins
210 Litre <b>POWERflow</b>	166 mins*	26 mins
300 Litre <b>POWERflow</b>	175 mins*	25 mins

Time to re-heat 70% to 60°C	Direct (3kW)	Indirect**
75 Litre <b>POWERflow</b>	73 mins	12 mins
120 Litre <b>POWERflow</b>	110 mins	16 mins
150 Litre <b>POWERflow</b>	101 mins*	18 mins
180 Litre <b>POWERflow</b>	125 mins*	19 mins
210 Litre <b>POWERflow</b>	128 mins*	20 mins
300 Litre <b>POWERflow</b>	135 mins*	21 mins

Heat Loss	Direct & Indirect	ERP Rating	
		Direct	Indirect
75 Litre <b>POWERflow</b>	43 Watts	B	B
120 Litre <b>POWERflow</b>	57 Watts	C	C
150 Litre <b>POWERflow</b>	64 Watts	C	C
180 Litre <b>POWERflow</b>	68 Watts	C	C
210 Litre <b>POWERflow</b>	71 Watts	C	C
300 Litre <b>POWERflow</b>	81 Watts	C	C

\*Using both Immersions

\*\*If adequate boiler power



# INDIRECT POWERflow WIRING DIAGRAM

## WIRING DIAGRAM TWO 2 PORT ZONE VALVE (S-PLAN) DUAL THERMOSTAT WIRING

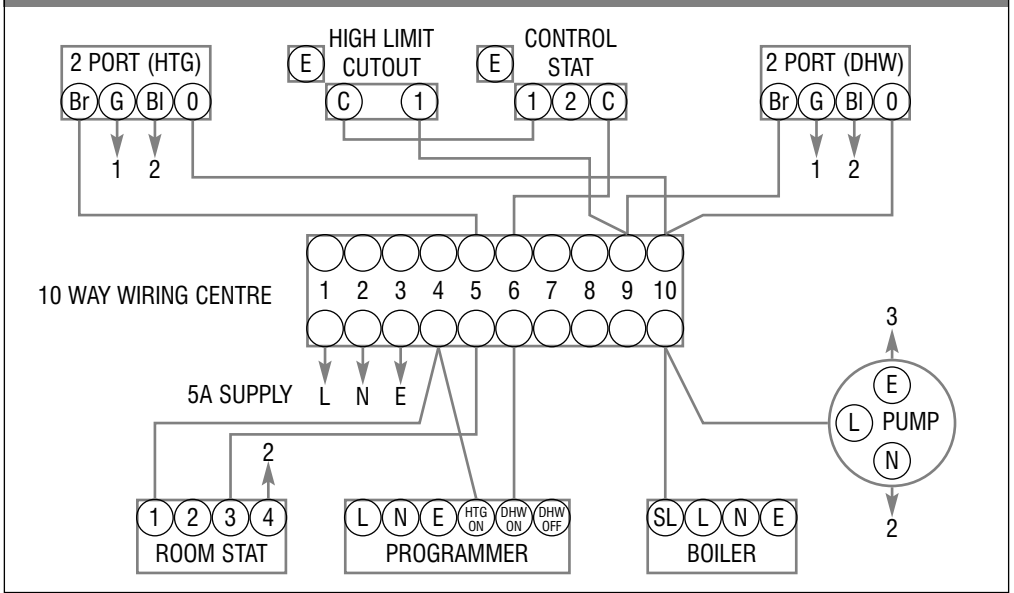

## WIRING DIAGRAM 3 PORT MID POSITION VALVE (Y-PLAN) + 2 PORT VALVE DUAL THERMOSTAT WIRING

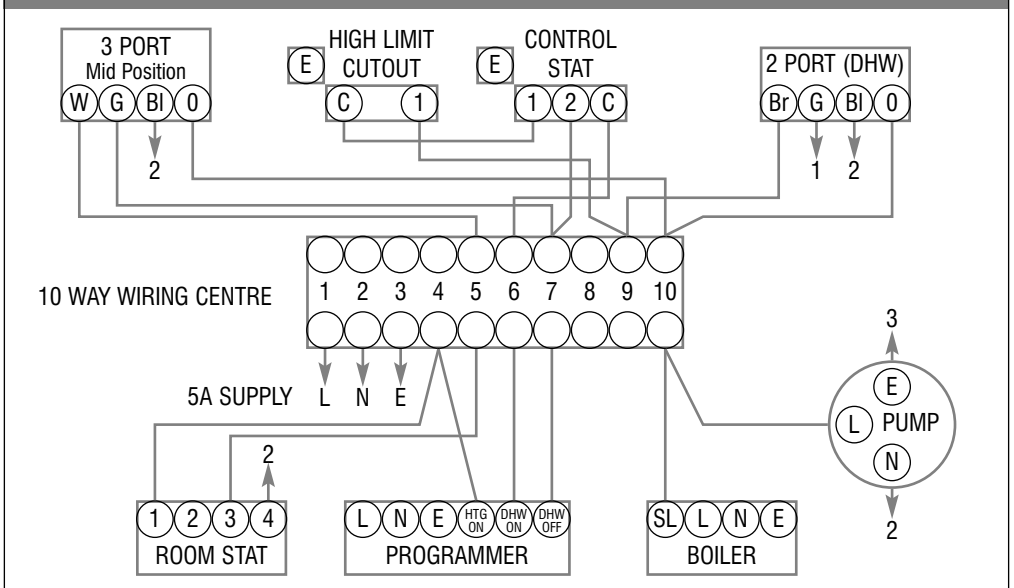

KEY: Bl=Blue, Br=Brown, C=Common Terminal, E=Earth, G=Grey, G/Y=Green/Yellow, L=Live, N=Neutral, O=Orange, SL=Switched Live, W=White  
 Note: The programmer and boiler power can be taken either from the Wiring Centre or from elsewhere as appropriate.

**Diagram 1 Typical discharge pipe arrangement**

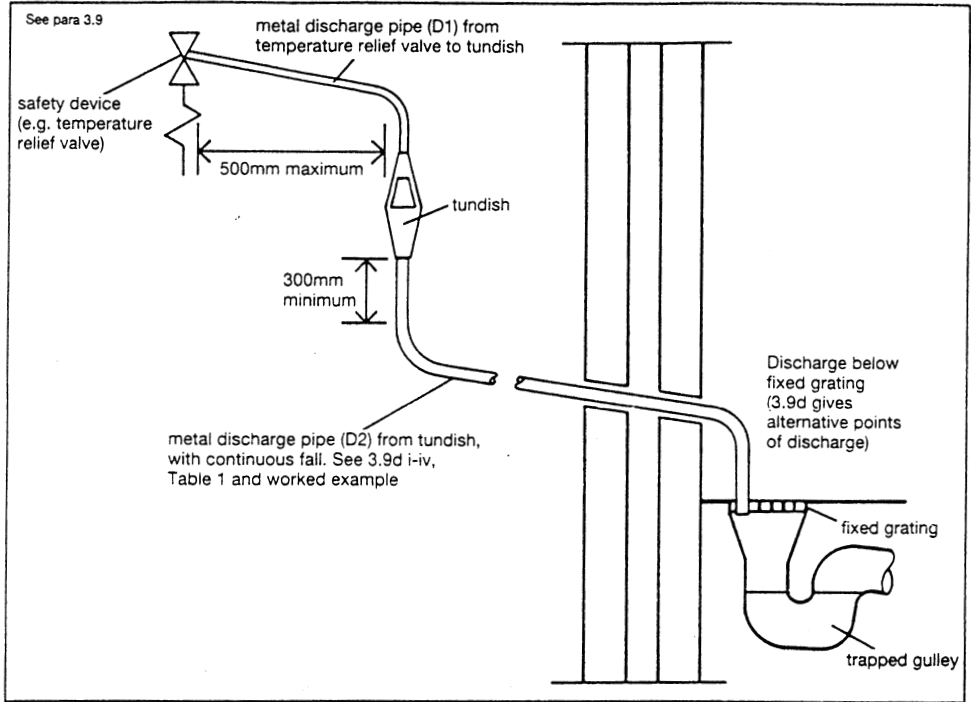

**Table 1 Sizing of copper discharge pipe 'D2' for common temperature relief valve outlet sizes**

Valve outlet size	Minimum size of discharge pipe D1*	Minimum size of discharge pipe D2* from tundish	Maximum resistance allowed, expressed as a length of straight pipe (i.e. no elbows or bends)	Resistance created by each elbow or bend
G <sup>1/2</sup>	15mm	22mm 28mm 35mm	up to 9m up to 18m up to 27m	0.8m 1.0m 1.4m
G <sup>3/4</sup>	22mm	28mm 35mm 42mm	up to 9m up to 18m up to 27m	1.0m 1.4m 1.7m
G 1	28mm	35mm 42mm 54mm	up to 9m up to 18m up to 27m	1.4m 1.7m 2.3m

\* see 3.5, 3.9, 3.9(a) and Diagram 1

**Worked example:-**

The example below is for a G<sup>1/2</sup> temperature relief valve with a discharge pipe (D2) having 4 No. elbows and length of 7m from the tundish to the point of discharge.

From Table 1:

Maximum resistance allowed for a straight length of 22mm copper discharge pipe (D2) from a G<sup>1/2</sup> temperature relief valve is: 9.0m

Subtract the resistance for 4 No. 22mm elbows at 0.8m each = 3.2m

Therefore the maximum permitted length equates to: 5.8m

5.8m is less than the actual length of 7m therefore calculate the next largest size.

Maximum resistance allowed for a straight length of 28mm pipe (D2) from a G<sup>1/2</sup> temperature relief valve equates to: 18m

Subtract the resistance for 4 No. 28mm elbows at 1.0m each = 4m

Therefore the maximum permitted length equates to: 14m

As the actual length is 7m, a 28mm (D2) copper pipe will be satisfactory.



## SOLAR COILS

The cylinder should be installed according to the standard POWERflow instructions.

### Single Coil Solar

The solar controller should be wired using the High Limit Thermostat to ensure power is cut to the solar pump, in the event of an overheat situation. Reference should be made to the solar equipment instructions.

### Dual Coil Solar

The upper Primary Coil, which is linked to a boiler, should be wired as per our standard wiring instructions on page 8. The lower Solar Coil should be wired as per the above instructions for Single Coil Solar. Reference should be made to the solar equipment instructions.

## HEATPUMP COILS

Certain Heatpumps cannot physically exceed a 60°C flow temperature and as such may not require a Motorised Zone Valve, or have alternative methods of control. A High Limit Thermostat is provided, to be used as required to prevent an overheat situation. Consult the Heat Pump's installation instructions.

## MULTIPLE CYLINDERS

Where 2 or more cylinders are installed together, please contact our technical department, for advice on the correct procedures - 01592 611123.

## MAINTENANCE

As per the instruction booklet and any requirements that the Solar Equipment dictates.



**The HWA Charter Statement requires that all members adhere to the following:**

- To supply fit for purpose products clearly and honestly described
- To supply products that meet or exceed appropriate standards and building and water regulations
- To provide pre and post technical support
- To provide clear and concise warranty details to customers



# McDonald Water Storage

QUEENSWAY INDUSTRIAL ESTATE,  
GLENROTHES FIFE KY7 5QF

Tel : 01592 611123 Fax : 01592 611166

Email : [sales@mcdonaldwaterstorage.com](mailto:sales@mcdonaldwaterstorage.com)

Internet : [www.mcdonaldwaterstorage.com](http://www.mcdonaldwaterstorage.com)